

Food & Nutrition Conference & Expo® (FNCE®) Display Regulations and Construction Guidelines

Exhibit Dates: October 6 – 8, 2024 | Location: Minneapolis Convention Center, Minneapolis, Minnesota

STANDARD BOOTH

One or more standard units in a straight line.

Height: Exhibit fixtures, components and identification signs will be permitted to a maximum height of 8'3" (2.5m).

Set-Back: All display fixtures over 4'0" (1.22m) in height and placed within 10 linear feet (3.05m) of an adjoining exhibit, must be confined to that area of exhibit space which is at least 5'0" (1.52m) from the aisle line.

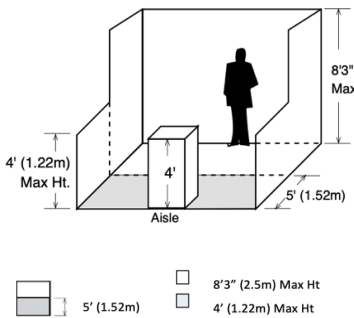

Intent: Each exhibitor is entitled to a reasonable sightline from the aisle regardless of the size of the exhibit space. Exhibitors with larger space—30 lineal feet (9.14m) or more—should also be able to effectively use as much of the total floor space as possible as long as they do not interfere with the rights of others. The limitation on display fixtures over 4'0" (1.22m) and within 10 lineal feet (3.05m) of a neighboring exhibit is intended to accomplish both of these aims.

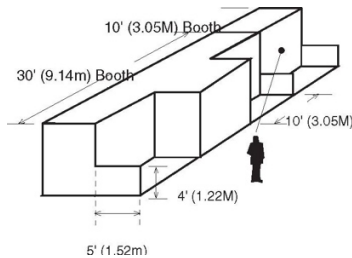

PERIMETER BOOTH

Standard booth located on the outer perimeter wall of the exhibit floor.

Height: Exhibit fixtures, components and identification signs will be permitted to a maximum height of 12'0" (3.66m) in perimeter wall booths.

Set-Back: All display fixtures over 4'0" (1.22m) in height and placed within 10 linear feet (3.05m) of an adjoining exhibit booth must be confined to that area of exhibit space which is at least 5'0" (1.52m) from the aisle line.

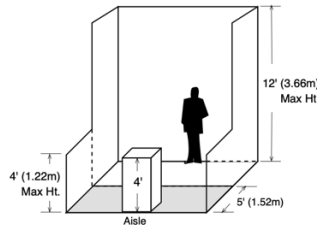

TOWERS

A free-standing exhibit component separate from the main exhibit fixture that is used for identification and display purposes only.

Height/Depth: Towers will be permitted to a height and depth that corresponds to the height and set-back regulations for the appropriate exhibit configuration of which they are a part. For example, towers that are a part of a peninsula exhibit will not exceed 16'0" (4.88m) in height and will not be placed within 10 lineal feet (3.05m) of a neighboring exhibit unless they are confined to that area of the exhibitor's space which is at least 5'0" (1.52m) from the aisle line to avoid blocking the sightline from the aisle to the adjoining booth.

Intent: Towers are part of the overall exhibit presentation and, therefore, must be treated as a component of the total exhibit configuration. The height and set-back regulations have been set to avoid undue competition between exhibitors to see who can go higher or be seen farther, while also assuring neighboring exhibitors the same reasonable sightline from the aisle as they would expect if they were adjacent to an exhibitor with a standard booth.

Structural Integrity: All towers that reach 12'0" (3.66m) must have drawings available for inspection during the time the exhibit is being erected, exhibited and dismantled at the show site. Drawings must include a signature or stamp of a reviewing structural engineer indicating that the structure designed is properly engineered for its proposed use, and a signature of an authorized official of the exhibit building company indicating that the structure is built in compliance with the details and specifications set forth on the drawings.

Intent: Exhibitors adjoining exhibits with towers are entitled to the same reasonable safety precautions they would expect if they were adjacent to a standard booth.

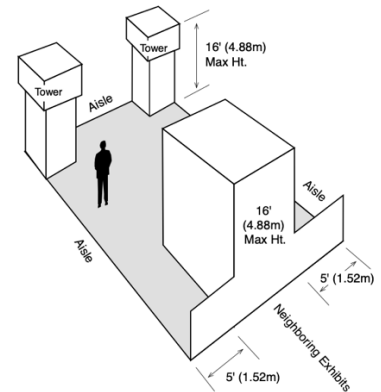

Food & Nutrition Conference & Expo® (FNCE®) Display Regulations and Construction Guidelines

Exhibit Dates: October 6 – 8, 2024 | Location: Minneapolis Convention Center, Minneapolis, Minnesota

ISLAND BOOTHS

Exhibit space 400 sq. ft. or greater, with aisles on all 4 sides.

Height: Exhibit fixtures and components will be permitted to a maximum height of 16'0" (4.88m) provided written approval is received from Show Management, 60 days prior to the opening of the Expo.

Intent: When an island booth exceeds 8'3" (2.5m), it does not interfere with other exhibitors because it obviously does not back up against another exhibitor's back wall. The extra height is often required in an island booth exhibit to permit the open walk-through approach normally used in this type of location. The 16'0" (4.88m) maximum height limitation has been set to avoid undue competition between exhibitors to see who can go higher or be seen farther negating the others' efforts. Also, the 16'0" (4.88m) high exhibit will fit into most exposition centers, thus permitting each exhibitor to the maximum use of his or her exhibit.

Set-Back: Because an island booth is automatically separated by the width of an aisle from all neighboring exhibits, there is no set-back regulation.

Structural Integrity: Exhibit fixtures and components exceeding 12'0" (3.66m) in height must have drawings available for inspection during the time the exhibit is being erected, exhibited and dismantled at the show site. Drawings must include a signature or stamp of a reviewing structural engineer indicating that the structure design is properly engineered for its proposed use, and a signature of an authorized official of the exhibit building company indicating that the structure is built in compliance with the details and specifications set forth on the drawings.

Exhibit fixtures and components exceeding 12' in height must submit detailed booth renderings to show management for final approval of booth layout to be sure all display regulations and construction guidelines are followed.

Intent: Exhibitors in the vicinity of island exhibits are entitled to the same reasonable safety precautions they would expect if they were adjacent to a standard booth.

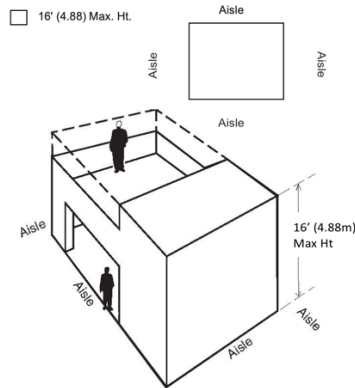

IMPORTANT: Exhibitors are cautioned when installing a display with a ceiling, canopy or multi-story exhibit to check with local fire departments and convention center to ensure that the display meets with the necessary fire safety precautions involving smoke alarms, fire extinguishers, sprinkler systems, etc.

HANGING SIGNS

An exhibit component suspended above an exhibit for the purpose of displaying graphics or identification. Hanging signs are permitted over Peninsula and Island Booths only.

Height: Hanging identification signs and graphics will be permitted to a maximum height of 20'0" (6.10m).

Set-Back: Hanging signs over Peninsula Booths must be set-back at least 25% of the booth width dimension from the back line of the booth (adjacent to adjoining booths).

Intent: Hanging signs, whether double-faced or not, should be set-back within the exhibitor's space so as not to detract from the overall impact of the exhibit that is directly adjacent.

Size: Hanging signs and graphics above an island booth will be permitted to the total length and width of the exhibitor's booth space.

Structural Integrity: All hanging signs must have drawings available for inspection during the time the component is being hung, suspended and removed at the show site that includes a signature or stamp of a reviewing structural engineer indicating that the stress points for hanging the sign have been properly engineered, and a signature of an authorized official of the exhibit building company indicating that the structure is built in compliance with the details and specifications set forth on the drawing. (Note: exhibitors are encouraged to use lightweight materials in the construction of a hanging sign to eliminate excessive stress to the facility ceiling structure.)

Intent: Exhibitors adjoining booths with hanging signs are entitled to the same reasonable safety precautions they would expect if they were adjacent to a standard booth.

Food & Nutrition Conference & Expo® (FNCE®) Display Regulations and Construction Guidelines

Exhibit Dates: October 6 – 8, 2024 | Location: Minneapolis Convention Center, Minneapolis, Minnesota

SAMPLING & DEMONSTRATIONS

The interaction of exhibit personnel and their audience through presentations, product demonstrations or sampling.

Regulation: Demonstration areas must be organized within the exhibitor's space so as not to interfere with any traffic aisles, and sampling or demonstration tables must be placed a minimum of 2'0" (60cm) from the aisle line. Should spectators or samplers interfere with the normal traffic flow in the aisle or overflow into neighboring exhibits, exposition management will have no alternative but to request that the presentation or sampling be eliminated.

Intent: The aisles are the property of the entire show, and each exhibitor has the responsibility to assure proper flow of traffic through the entire show. When large crowds gather to watch a demonstration or for sampling, and interfere with the flow of traffic down aisles, or create excessive crowds in neighboring booths, it is an infringement on the rights of other exhibitors. Aisles must not be obstructed at any time.

Sound: Exhibitors must police their own booths to be sure the noise levels from demonstrations or sound systems is kept to a minimum and does not interfere with others. Remember the use of sound systems or equipment producing sound is an exception to the rule, not a right. Show management reserves the right to determine at what point sound constitutes interference with others and must be discontinued.

Safety Precautions: All product demonstration involving any moving and potentially hazardous machines, displays, or parts, must have hazard barriers to prevent accidental injury to spectators. Demonstrations must always be supervised by exhibitor personnel who can stop the demonstration in the event of an emergency and all demonstrations involving potentially hazardous by-products, such as dust, fumes, sparks, or flames, must be approved in writing by show management 60 days prior to the show.

